

BLIND RIVET HAND TOOLS

NTS (with self opening spring)

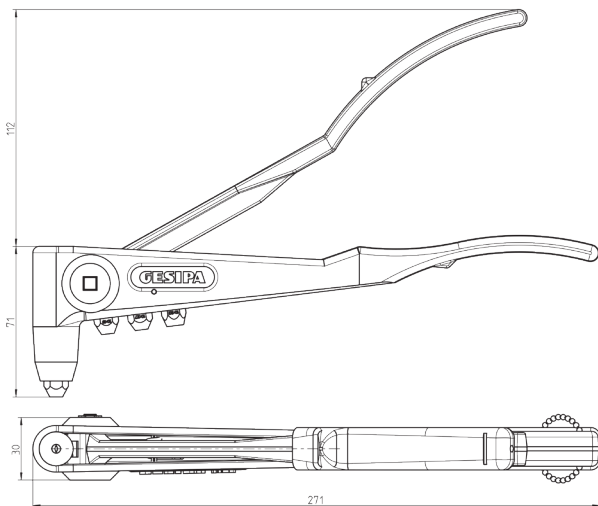

No. 143 4028



Dimensions in mm

TECHNICAL DATA

Weight: 480 g
Total length: 271 mm
Stroke: 8 mm

WORKING RANGE

Blind rivets up to 5 mm Ø aluminium
and 4 mm Ø steel and stainless steel
(max. mandrel Ø 3.0 mm)

SCOPE OF DELIVERY

Nosepieces: 10/18, 10/24, 10/27 and 10/32
1 maintenance wrench, operating instructions with
spare parts list

ADVANTAGES

- Body casing in high-quality die cast aluminium
- Body head made of forged steel
- Narrow head for difficult to access rivet locations
- Opening spring for automatic ejection of the mandrel
- Ergonomic handles

JAWS (2-PARTS)

For NTS, NTX, NTX-F and Flipper®

No. 143 4071



73

Nosepiece assignment for
NTS, NTX and NTX-F can
be found on **page 73**.