

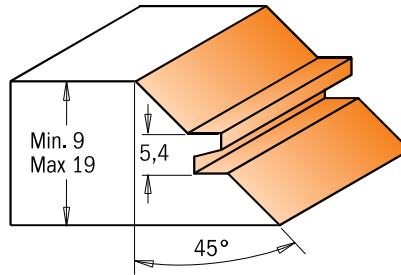

8/955.504

These are the ultimate bits to craft sturdy miter joints thanks to anti-kickback design and tough tungsten carbide cutting edges. By adding a second smaller bit, you can mill anywhere from 9,5mm to 28,5mm in thickness. A quick and easy way to accurately create boxes, stretcher bars, frames and any assortment of right angle or parallel joint projects.

You also have the advantage of using the same bit for parallel joinery projects. To mill sturdy parallel glue joints follow step 1 shown in the illustration with the inside face of the workpiece laid flat on the table and centred to the bit. To make the second part, lay the workpiece flat on the table and centred to the bit. Mill with the inside face-up.



8/955.503

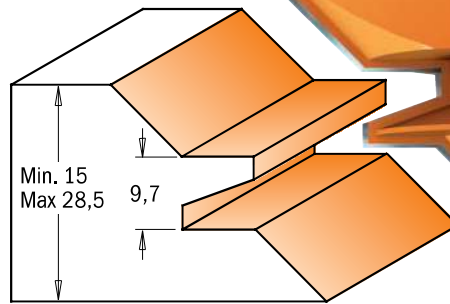

Drawing is 1:1 scale

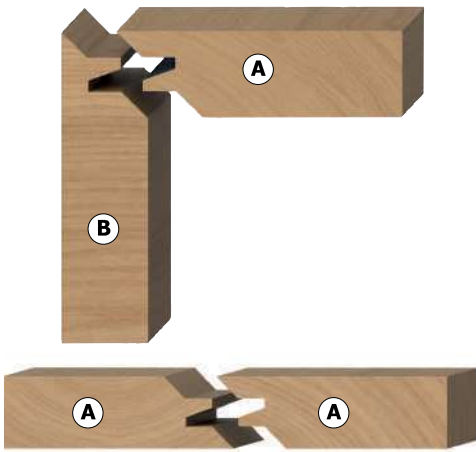

FOR MITER AND PARALLEL GLUE JOINTS USING 19MM BOARD

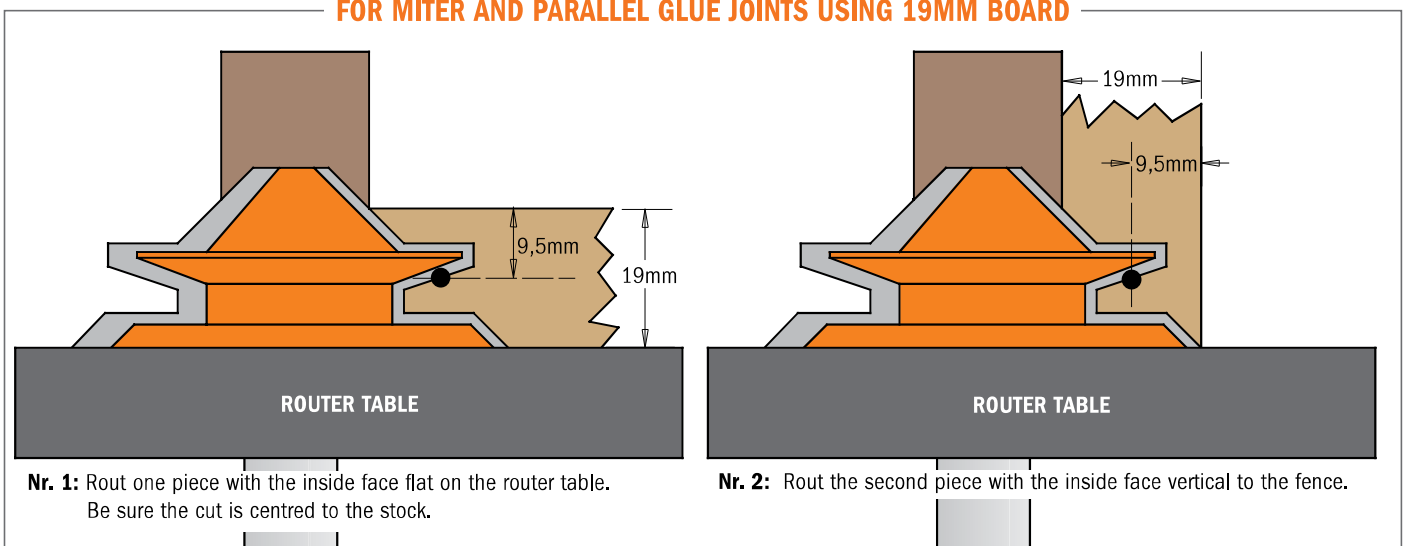

Nr. 1: Rout one piece with the inside face flat on the router table. Be sure the cut is centred to the stock.

Nr. 2: Rout the second piece with the inside face vertical to the fence.

D mm	I mm	A	T ₁ mm	L mm		ORDER NO. S=Ø8mm	ORDER NO. S=Ø12mm	ORDER NO. S=Ø12,7mm
44,5	19	45°	9 ÷ 18	58	5	955.009.11		
50,8	21	45°	9,5 ÷ 19	60,3	5		955.504.11	855.504.11
70	30	45°	15 ÷ 28,5	70	5		955.503.11	855.503.11